

## KX015-4/KX016-4/KX018-4 Service Alert Clearance Procedure

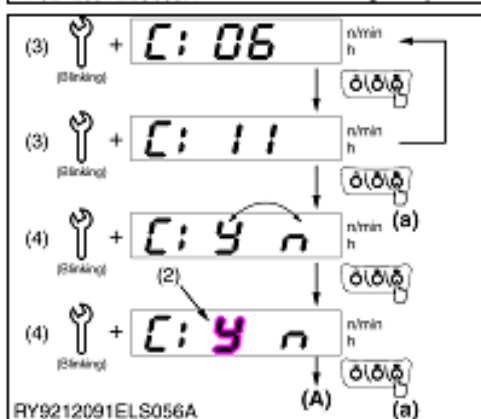
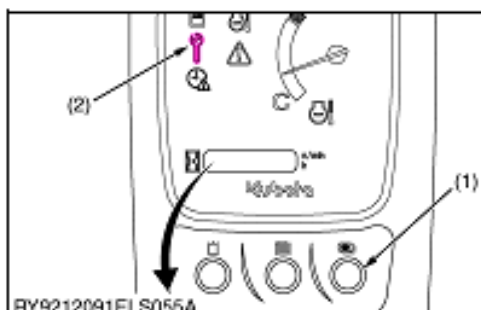
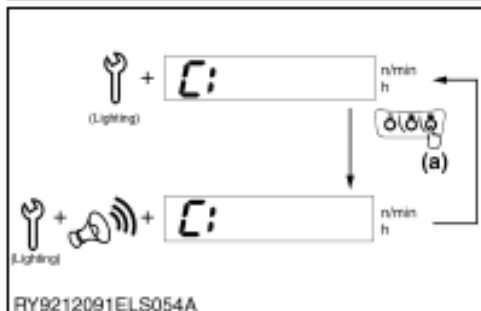
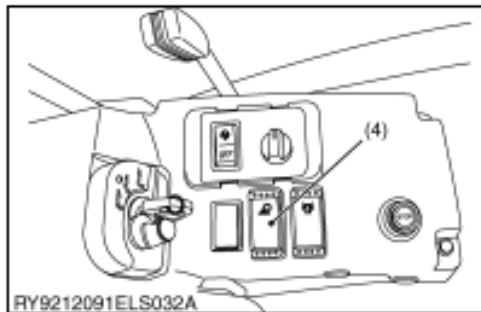
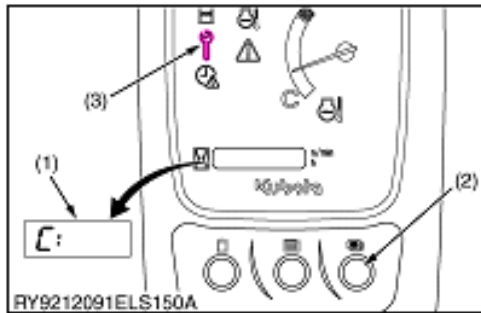

### Switching to the Periodic Inspection Item Display Screen

1. After switching to the user settings mode, press SW2 and select the periodic inspection mode.
2. After turning the work light switch ON/OFF once, pressing and holding SW2 switches the display to the periodic inspection item display screen.

- If there are no periodic inspection items, when SW2 is held down, the buzzer will beep two times and the screen display will not change.

- (1) Periodic Inspection Mode (a) Press and hold SW2  
 (2) Toggle display switch (SW2)  
 (3) Periodic inspection light  
 (4) Work light switch

RY9212091EL80037U80

### Checking Periodic Inspection Items and Operations after the Inspection

1. When there are periodic inspection items, the periodic inspection lamp blinks and the code(s) of items to be inspected are displayed on the LCD screen. (For information on the codes displayed and the periodic inspection items, refer to "Table of Periodic Inspection Items.")
2. If there are multiple places to be inspected, pressing SW2 toggles the code display in a loop.
3. Pressing and holding SW2 while the code of a periodic inspection item is displayed switches the screen to the part inspection check screen.
4. Pressing SW2 toggles the selection between YES and NO and the selected item blinks.
5. Once a periodic inspection is complete, select YES and then press and hold SW2 to confirm it. After the buzzer beeps several times and the inspection item disappears, return to the normal mode.
6. If you select NO and then press and hold SW2, thus confirming it, you can allow the periodic inspection item to continue to be displayed.

- (1) Toggle display switch (SW2) (a) Press and hold SW2  
 (2) Blinks  
 (3) Periodic inspection item (A) Normal mode  
 (4) Checking inspection individually